

CAVA

CAVA 1.18.1 – What's new

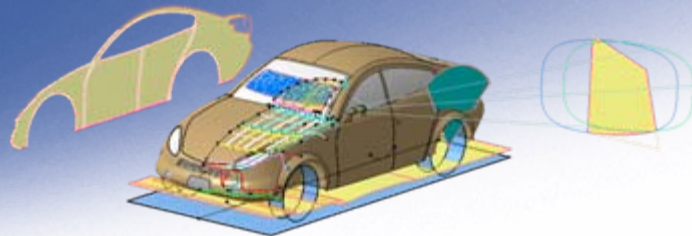





TRANSCAT

A DASSAULT SYSTEMES COMPANY

Tools Options - Default

 New option to define up to 4 extensions to the feature name in navigation tree

-  *Used standard*
-  *Used base data*
-  *Used Seat*
-  *Used Loading*

Options for feature names

Extend feature name by:

1: STANDARD # 2: BASE DATA 3: UNDEFINED 4: LOADING

Separator: #

 CAVA Fields Of View.1 (EG EWG 78/318 (Wiper)#CAVA Base Data.1)

Performance improvements for different features

-  Pedestrian Protection
-  Safety Radius
-  3D Direct View

Change Geometrical Set for CAVA feature

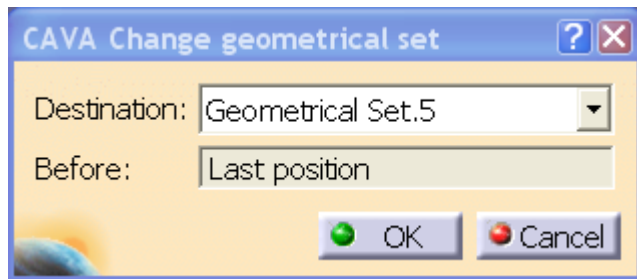

Enhancement for feature “Child Protection“

👤 New standard “FMVSS 225 (since 1. Sept. 2004)”

👤 Slightly different definition of cut out area

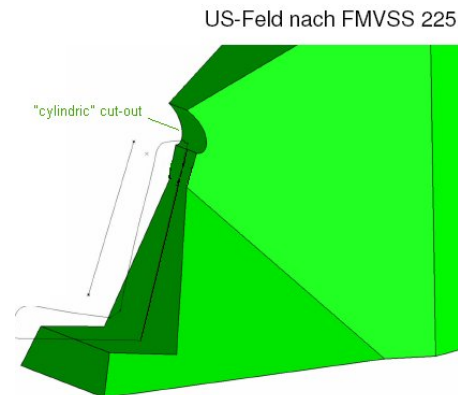

Enhancement for feature “Lamp Position”

👤 New checks for proper position

- 🔧 *Dependency between different lamp types*
- 🔧 *Dependency to car geometry*

- 🔧 *Visibility check for Rear Reflector*
- 🔧 *Visibility check for Reversing light*
- 🔧 *Visibility Check for Side Turn Indicator*

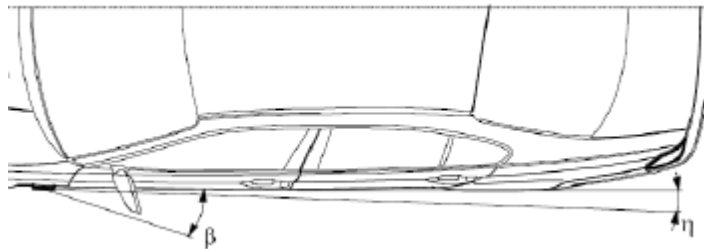
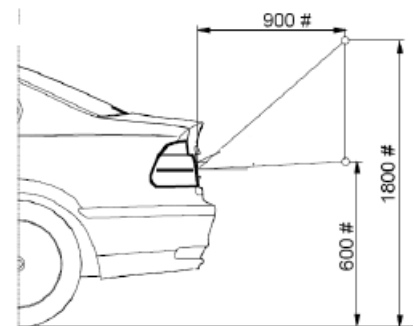
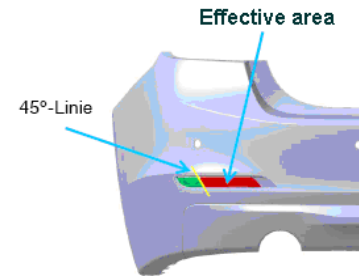

Enhancement for feature “Head Contour”

- Option to display the required position (*surface / wire*), if *roof geometry is selected*
- Geometry is moved in perpendicular direction to reach the required position

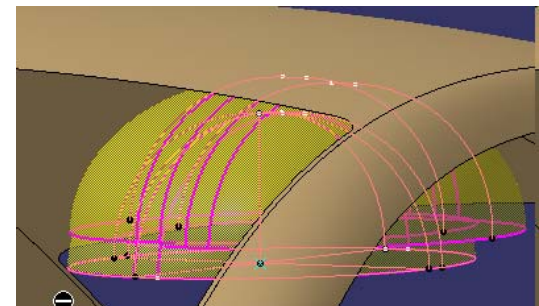
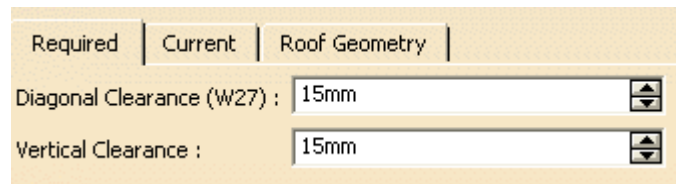

Enhancement for feature “Fields of View“

New amendment for ECE R43 - use centroid driver

-  a new amendment (probably starting in 11/2011) defining the A-area for centric driver position

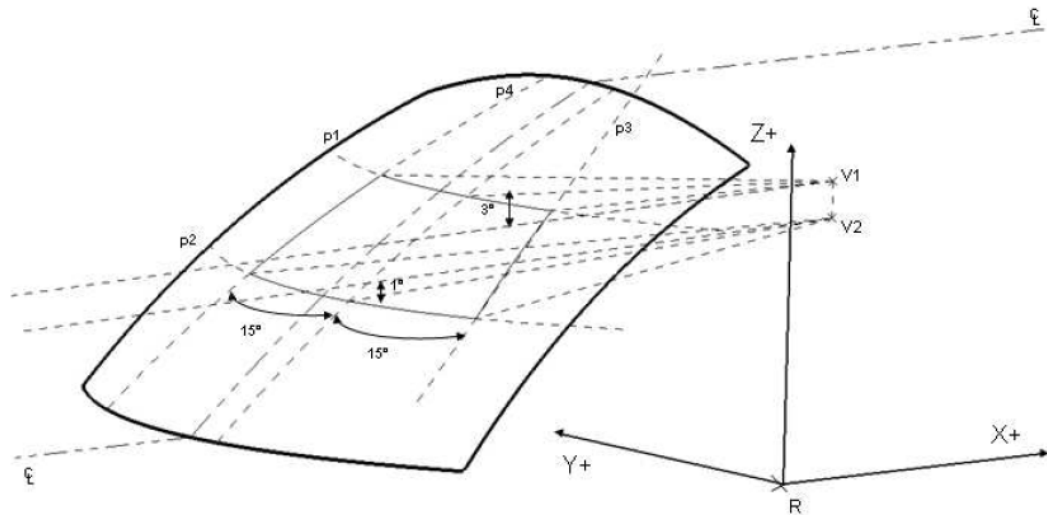

Enhancement for feature “Vision Planes” (1/2)

 New Option to select and check geometry

Obstruction Check

Steering Wheel:

Create SW Plane Check 'S' Area Allowed Coverage: %

Create 'S' Area Create Blocking Elements Fill Blocking Elements

Windscreen:

General **Blocking Elements**

| Element | Type |
|---------|---------|
| GPS | GEOM 2D |



Enhancement for feature “Vision Planes“ (2/2)

New Standard “ECE-R 125 paragraph 5.1.3.2.

Calculation of area “S”

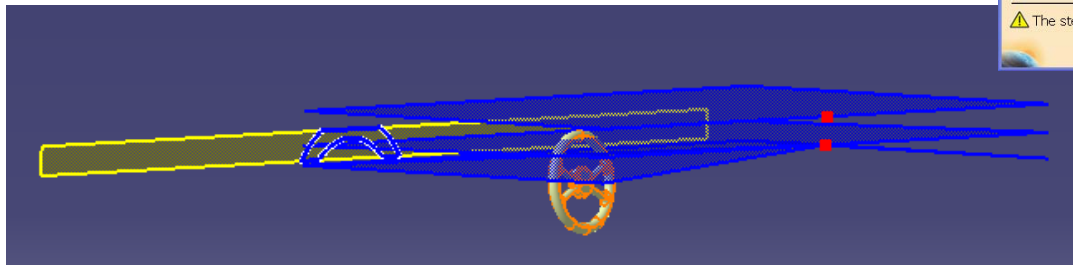
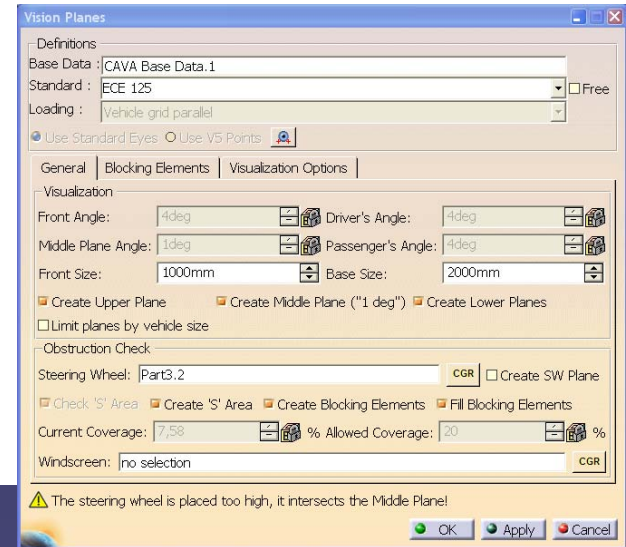
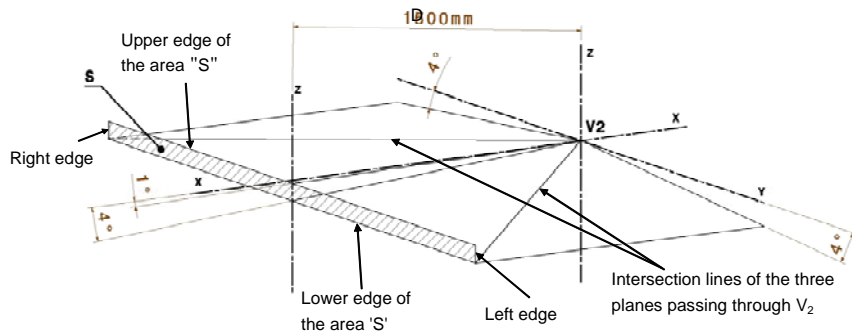

Enhancements for feature “Close Range Visibility“



New option to add several demo cylinder at a time

| Name | Position (0...1) | Type | Show | Show ray |
|------------------|------------------|----------|-------------------------------------|-------------------------------------|
| Demo Cylinder.1 | 0 | Simple | <input checked="" type="checkbox"/> | <input checked="" type="checkbox"/> |
| Demo Cylinder.2 | 0,111111 | Detailed | <input checked="" type="checkbox"/> | <input checked="" type="checkbox"/> |
| Demo Cylinder.3 | 0,222222 | Detailed | <input checked="" type="checkbox"/> | <input checked="" type="checkbox"/> |
| Demo Cylinder.4 | 0,333333 | Detailed | <input checked="" type="checkbox"/> | <input checked="" type="checkbox"/> |
| Demo Cylinder.5 | 0,444444 | Detailed | <input checked="" type="checkbox"/> | <input checked="" type="checkbox"/> |
| Demo Cylinder.6 | 0,555556 | Detailed | <input checked="" type="checkbox"/> | <input checked="" type="checkbox"/> |
| Demo Cylinder.7 | 0,666667 | Detailed | <input checked="" type="checkbox"/> | <input checked="" type="checkbox"/> |
| Demo Cylinder.8 | 0,777778 | Detailed | <input checked="" type="checkbox"/> | <input checked="" type="checkbox"/> |
| Demo Cylinder.9 | 0,888889 | Detailed | <input checked="" type="checkbox"/> | <input checked="" type="checkbox"/> |
| Demo Cylinder.10 | 1 | Detailed | <input checked="" type="checkbox"/> | <input checked="" type="checkbox"/> |

Number: 10 Position (0...1): 1 Type: Detailed

Show demo cylinder Show demo cylinder ray

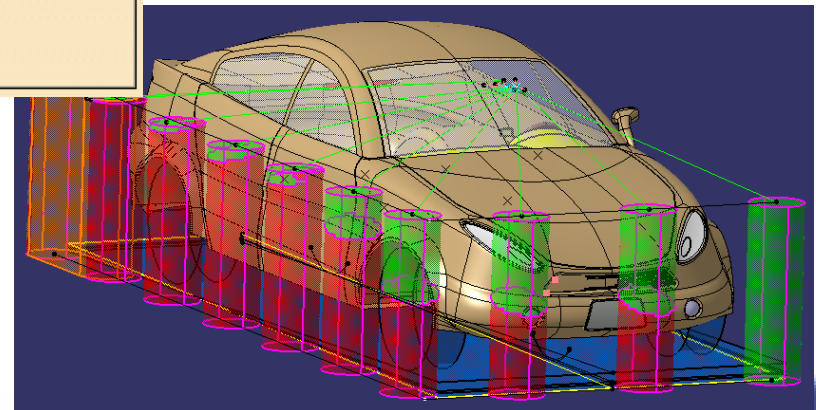

CAVA – Vision – Rear View Mirror



Improved User Interface

- Minimize number of tab pages
- Additional visualization to clarify the rotation direction of the mirror glass when using the arrow buttons
- New 2D viewer GUI, displaying the view on the mirror
 - See next slides for more details

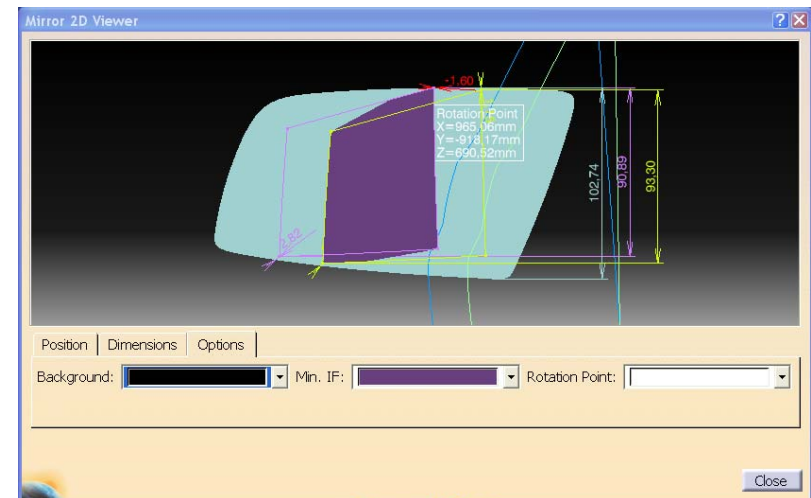
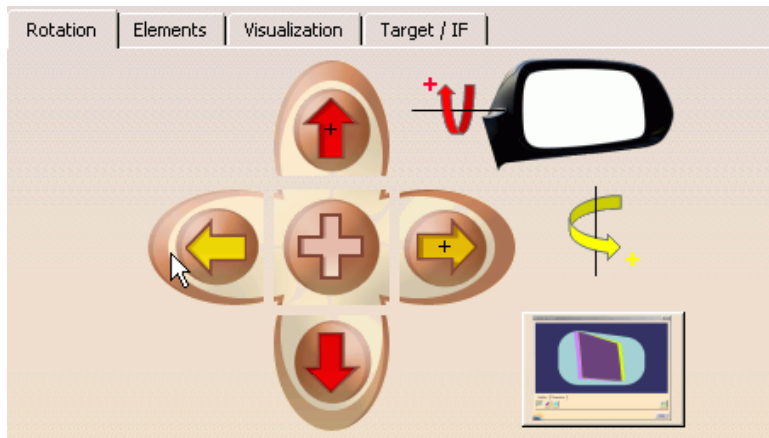

CAVA – Vision – Rear View Mirror



2D Viewer for Rear View Mirror (1/4)

- Can be opened parallel to Mirror GUI
- Improved positioning of the mirror

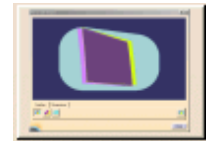

Automatic:

Topmost IF point on topmost point of mirror

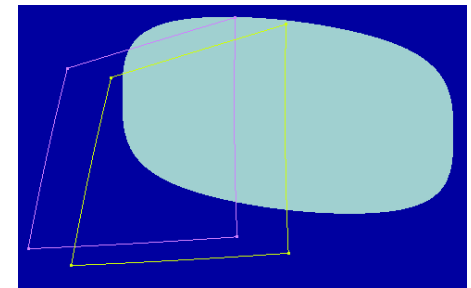
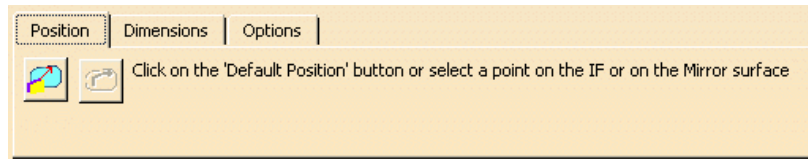

By mouse indication:

Selected IF point placed on selected point of mirror

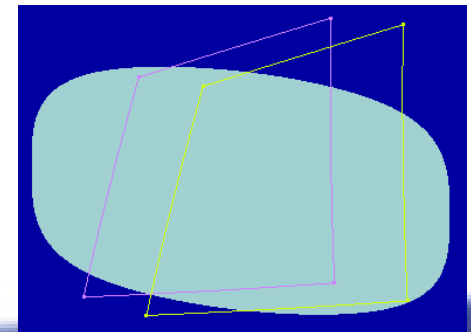
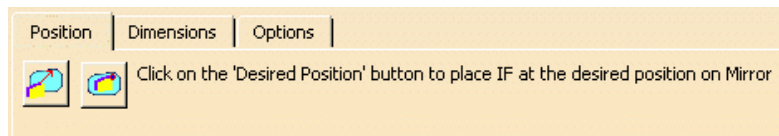

CAVA – Vision – Rear View Mirror



2D Viewer for Rear View Mirror (2/4)

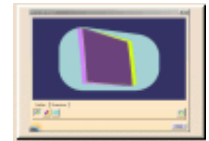

Different options to show the IF fields

Show single field for left and right eye or ambinocular

Show minimum resulting IF

Different options to show the blocking elements

Show single field for left and right eye or ambinocular

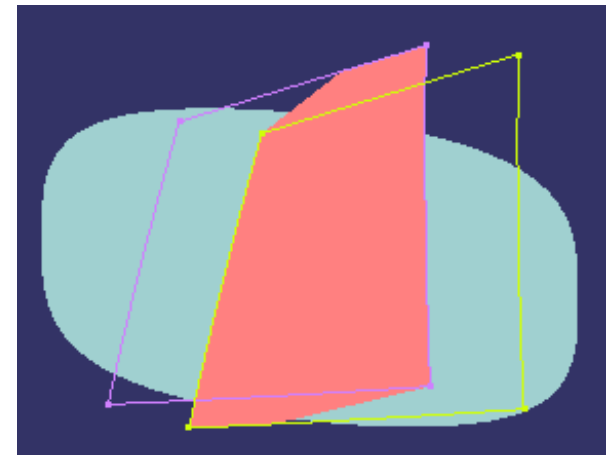
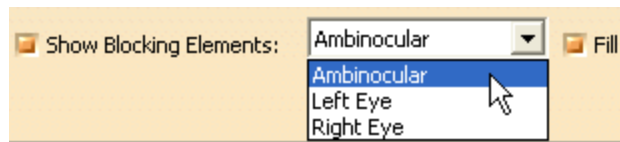
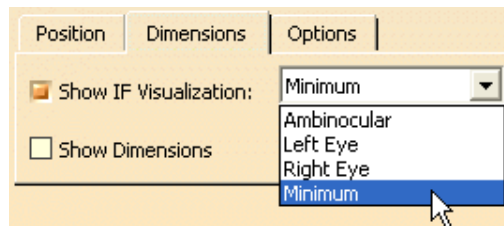

CAVA – Vision – Rear View Mirror



2D Viewer for Rear View Mirror (3/4)

Show dimensions for documentation

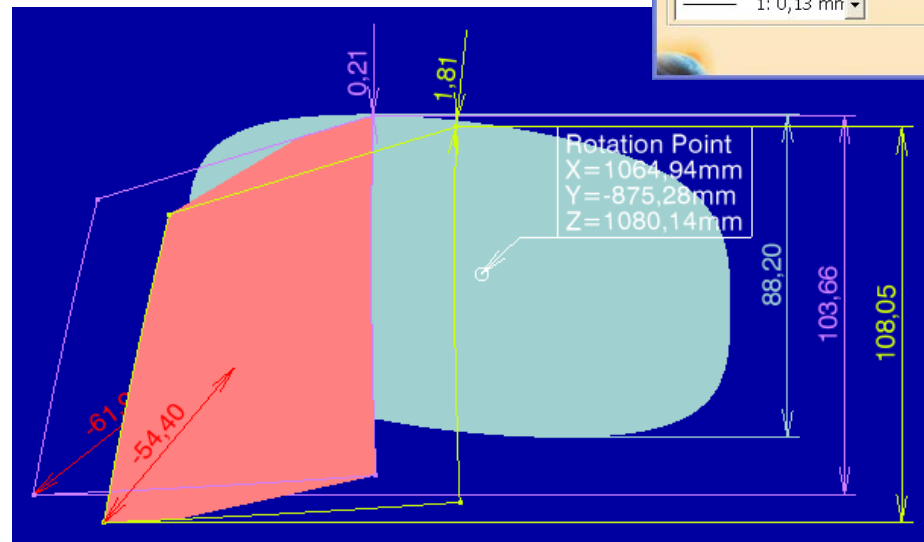
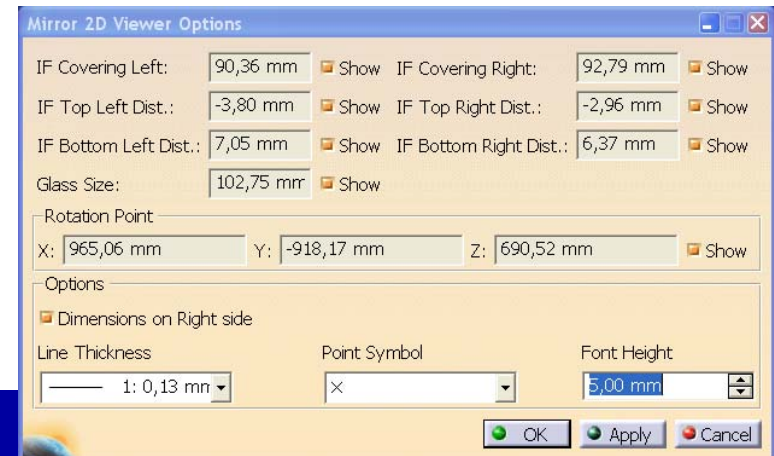
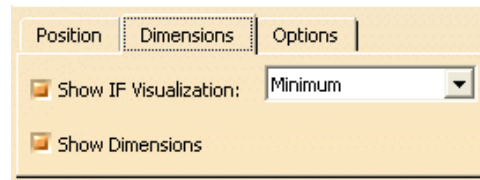

2D Viewer for Rear View Mirror (4/4)

 Capture image from 2D viewer and save in different file formats 



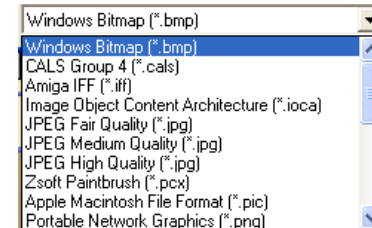
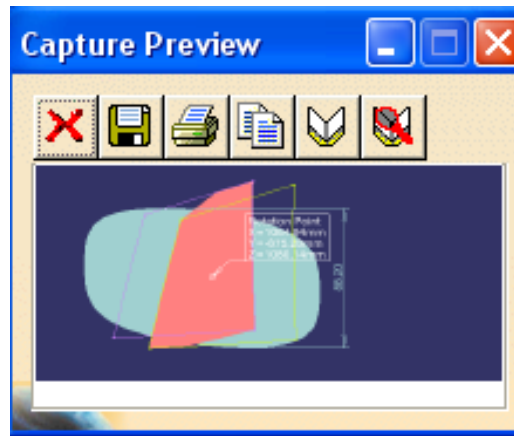
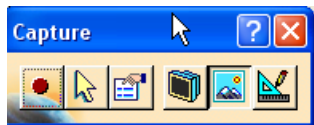

 *Similar to Plane View Feature*





CAVA – Vision – Rear View Mirror







New option to define the actuator coordinate system by

-  Default axis system (vehicle system - common behavior)
-  User defined Axis System
-  Vertical (fix) and a horizontal axis (as V5 lines)
-  Additional output of the absolute rotation angle
 -  *V5 parameter – can be linked to formula,...*



Rotation Angle around Axis

Vertical:  Horizontal: 

Abs. Vert.:   Abs. Hor.:  

Mirror Axis System

 Used internal Default Axis System



Mirror Axis System   

Default Axis System

Axis System:

Vertical (fixed) Axis:

Horizontal Axis:

 

CAVA – Vision – Rear View Mirror



New calculation of the 'View Angle'

-  *Angle between line from the middle eye to rotation point projected on road plane and mid ZX plane*

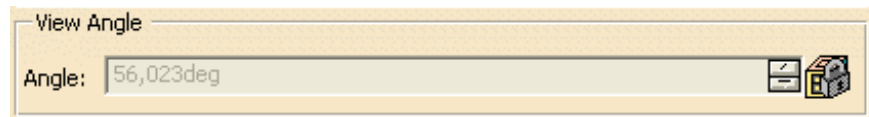

Enhancements for feature “Pedestrian Protection“

- 👤 New procedure to generate a grid on frontal upper vehicle surface for Euro NCAP Standard

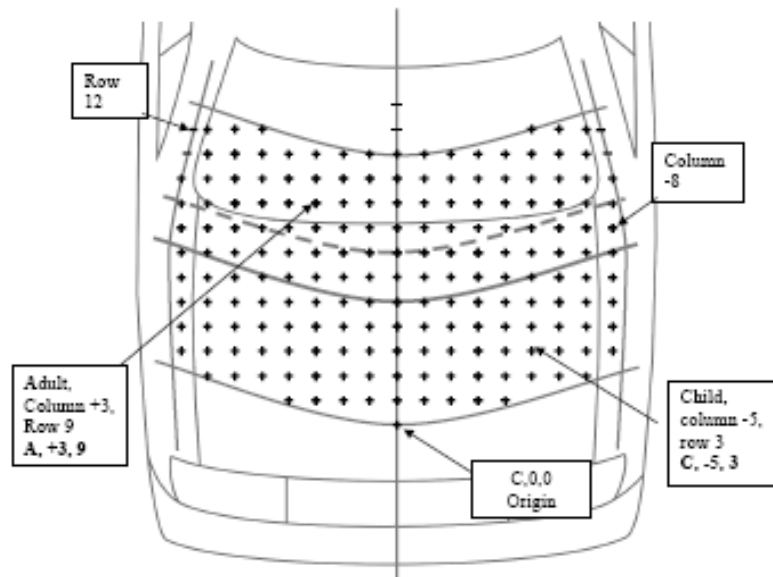

TRANSCAT

THANK YOU

www.transcat-plm.com